

NLZ Motor System

# NLZ E/NLZ

OPERATION  
MANUAL



# Contents

<b>1. Introduction .....</b>	<b>2</b>	<b>5. Post-use Maintenance .....</b>	<b>39</b>
1-1 Outline.....	2	5-1 Cleaning at point-of use (Motor) .....	39
1-2 User and Indication for Use .....	2	5-2 Cleaning, Disinfecting (Motor).....	40
1-3 Precautions for handling and operation .....	3	5-3 Packaging, Sterilizing, .....	41
1-4 Classification of Equipment .....	6	Drying and Storage (Motor)	
<b>2. Components .....</b>	<b>7</b>	<b>6. Maintenance .....</b>	<b>42</b>
2-1 List of components .....	7	6-1 Replacing the O-rings (Motor insert) .....	42
2-2 Part Names of Control Unit and Main Unit .....	8	6-2 Replacing the O-rings (Motor rear side).....	43
<b>3. Preparations for Use .....</b>	<b>12</b>	6-3 Periodical Maintenance Checks .....	43
3-1 Installing the Main Unit and the Control Unit.....	12	<b>7. Troubleshooting .....</b>	<b>44</b>
3-2 Connecting the Tubing .....	13	7-1 Error Code .....	44
3-3 Connecting the Motor Cord .....	14	7-2 Troubles and Actions.....	45
3-4 Connecting the AC Adapter .....	14	<b>8. Specifications .....</b>	<b>46</b>
3-5 Connecting the AC Power Cord.....	15	8-1 Specifications.....	46
3-6 Connecting / disconnecting the motor.....	15	8-2 Symbol .....	47
and motor cord		<b>9. After-sales Service.....</b>	<b>48</b>
3-7 Using barrier sleeve (motor cord). .....	16	9-1 Warranty.....	48
3-8 Using barrier film (control unit).....	16	9-2 Spare Parts List.....	48
3-9 Connecting / disconnecting the motor.....	17	9-3 Option Parts List.....	49
and the handpiece (option)		9-4 Disposing product.....	49
3-10 Changing the settings for various functions .....	18	<b>10. EMC Information .....</b>	<b>50</b>
3-11 Check before treatment .....	22	(Electromagnetic Compatibility Information)	
<b>4. Operation Procedure .....</b>	<b>23</b>		
4-1 General Application Mode .....	24		
4-2 Rotary Endo Mode (NLZ E only) .....	25		
4-3 Reciprocating Endo Mode (NLZ E only).....	28		
4-4 Contra-Check Function .....	29		
4-5 Sound Volume .....	34		
(When the load exceeds the set torque limit value, Error etc.)			
4-6 Last Memory Function .....	35		
4-7 Initializing Program .....	35		
(Restoring the Factory Setting)			
4-8 Overheat Prevention .....	37		

# 1 Introduction

Thank you for purchasing the NSK NLZ E / NLZ motor system.

This product can be connected to a dental unit (air unit), which is currently in use, to equip it with a brushless electric micromotor with LED light.

Please read this Operation Manual carefully before use for operation instructions and maintenance guidelines to increase overall product life span. Keep this Operation Manual in a handy place for future reference.

## 1-1 Outline

NLZ Motor Systems are available in two models.

NLZ Motor Set, which consists of the main unit, the control unit (Endo function not available) and the Motor.

NLZ E Motor Set, which consists of the main unit, the control unit (Endo function available) and the Motor.



Optional



## 1-2 User and Indications for Use

### User:

Dental professionals

### Indications for Use:

The NLZ Motor System is intended for use by dental professionals in the performance of dental restoration, prophylaxis and endodontic procedures.

The NLZ Endo is intended for use by dental professionals in the performance of dental endodontic procedures.

### 1-3 Precautions for handling and operation

- Please read these precautions carefully and use only as intended or instructed.
- Safety instructions are intended to avoid potential hazards that could result in personal injury or damage to the device. Safety instructions are classified as follows in accordance with the seriousness of the risk.

Class	Degree of Risk
<b>⚠ WARNING</b>	Hazard that could result in serious injury or damage to the device if the safety instructions are not correctly followed.
<b>⚠ CAUTION</b>	Hazard that could result in light or moderate injury or damage to the device if the safety instructions are not correctly followed.
<b>NOTICE</b>	General product specification information highlighted to avoid product malfunction and performance reduction.

#### **⚠ WARNING**

- Do not disassemble, adjust or alter the motor or handpiece except as recommended by NSK in this Operation Manual.
- Do not handle the AC power cord or any other components of this system with wet hands. Touching electrical devices with wet hands may result in electric shock.
- Avoid splashing water into or near the control unit. Otherwise it could cause short circuits and lead to fire and/or electric shock.
- Do not allow any impact on to the product. Do not drop the product. Doing so might cause electric shock or malfunction.
- Do not operate this product close to patients with cardiac pacemakers. It may affect the function of pacemaker.
- Keep this product away from explosive substances and flammable materials. Also, do not use this product on or near patients who have been administered flammable anesthesia, such as dinitrogen monoxide.
- If the product overheats or smells like burning, immediately turn OFF the power switch, disconnect the power plug (by pulling the plug, not the cable) and contact your Authorized NSK Dealer.
- When using of this equipment adjacent to or stacked with other equipment, this equipment and the other equipment should be observed to verify that they are operating normally.
- Connect the handpiece to the motor, rotate before using to check for motor/handpiece vibration, noise or overheating. If any abnormalities occur, stop using the product immediately and contact your Authorized NSK Dealer. (Refer to "3-11 Check before treatment")
- Should the product function abnormally during use, stop using the product immediately and contact your Authorized NSK Dealer.
- If the product has not been used for a long period, rotate the motor/handpiece and check for noise, vibration or overheating before use.

<Motor, Handpiece (Option)>

- Immediately after a treatment (within 1 hour), perform maintenance and then store the motor and the handpiece. Failure to properly maintain the motor and the handpiece may lead to overheating, causing infection, burn injuries or product failure. Follow maintenance procedures as instructed in this manual and operation manual of the handpiece.

### CAUTION

- Place the most priority on patient safety.
  - The product is designed only for clinical dental use by qualified personnel. This product must not be used for oral surgery, implants or dental laboratory work.
  - This product may be used only by Dental Professionals, such as Dentists in dental clinics or other medical premises including hospitals.
  - The product must be used in a dental clinic, hospital or other dental institution.
  - The user shall be responsible for any judgment that relates to the application of this product to a patient.
  - The user is responsible for the operational control, maintenance and continual inspection of this product.
  - Do not use the product outside the specified use environment. It may cause malfunction. (Refer to “8-1 Specifications”)
  - Operators and all others in the area must wear eye protection and a mask when operating this handpiece.
  - Use only the AC adaptor, AC power cord provided with the product. Never use other AC adapters. Doing so might cause a malfunction.
  - The AC power cord is the means to cut off commercial power supply. Make sure that the AC power cord can be pulled out from the power outlet without delay in an emergency. Do not place any articles within 15cm of the AC power cord.
  - When dirt adheres to the control unit, main unit or AC Adaptor, turn OFF the power, wipe off the dirt with a firmly wrung moist cloth, and then wipe thoroughly with a soft, dry cloth.
  - Do not use the following fluids to wipe, immerse or clean the product; strong / super acid water, strong acid / alkaline chemicals, chlorine-containing solutions, solvents such as benzene or thinner. (Refer to “5. Post-use Maintenance”)
  - Perform regular function and maintenance checks. (Refer to “6-3 Periodical Maintenance Checks”)
  - This product is rated Medical Electrical equipment. EMC (Electromagnetic compatibility) is described in the documentation included. Installation and use of this product requires special precautions regarding EMC according to the EMC information. (Refer to “10. EMC Information (Electromagnetic Compatibility Information”)
  - Portable and mobile RF communications equipment can affect Medical Electrical equipment. Do not use RF equipment near the product.
  - Use only authorized components. Use of other components might impair the EMC performance of the product.
  - Make sure that each part is properly connected. Improper connections might cause faulty operation, LED lighting failure and water or air leakage.
  - The AC power cord included with the product has the length of 2 meters. Bundle and fix the extra cord to prevent the operator or the patient from inadvertently stepping on it.
- <Control Unit, Main Unit>
- When disconnecting the AC power cord, motor cord or other cords, hold the cords by their plug and pull the plug out. Holding and pulling the cord might snap the wiring in the cord and cause a malfunction.
  - When installing the control unit, motor and other components, provide enough room to avoid bending or twisting the tubing or the cord.
  - Do not sterilize the control unit, main unit, AC adaptor, AC power cord, motor cord.



**<Motor, Handpiece (Option)>**

- The output torque changes according to the type of handpiece connected to the motor, operating conditions and other factors. Be sure to use a handpiece made by NSK. (Refer to "4-4 Contra-Check Function") Use of a handpiece made by a different manufacturer might cause trouble such as disparity between the preset and the output torque.
- Ensure that the motor has completely stopped rotating before handling. Connecting or disconnecting the handpiece while the motor is rotating may result in injuries or damage the handpiece.
- Do not point the light illuminated from the motor and handpiece directly into patient's or operator's eyes. Doing so might damage the eyes.
- The motor is delivered in a non-sterile condition and must be performed steam sterilization prior to use.
- Do not lubricate the motor. It may cause overheating and product failure.
- Use moisture- and dust-free air as the supply air. Mixing in of moisture might cause malfunction or heat generation.
- Connect only ISO 9168-compliant, Type 2 (Midwest 4 holes), or Type 3 (ISO-compliant standard 4 holes with light) tubing.
- Make sure to supply coolant air. Otherwise, the motor/handpiece surface might reach a temperature of 51°C or higher.

**NOTICE**

- During operation, the motor and motor cord may affect computers, LAN cables in the vicinity of use. Noise could be heard during operation near a radio receiver.
- Use the "Power Key" to turn ON/OFF the power on a daily basis. If the system is not used for a long period of time or if the system malfunctions, turn OFF the power of the main unit, disconnect the power cord, and drain water from main unit, tubing and motor cord.
- For details on handling the handpiece, refer to the Operation Manual of the handpiece.
- Only authorized service personnel should inspect inside the product by following the instructions in the service manual. Leave the product with your Authorized NSK Dealer, if necessary.
- No special training is required to operate this device.
- Drain water from the main unit, tubing and motor cord, if the main unit is not to be used for a long time.

### 1-4 Classification of Equipment

- Type of protection against electric shock:
  - Class II equipment 
- Degree of protection against electric shock:
  - Type B applied part:  (Applied parts: Motor, Handpiece)
- Method of sterilization or disinfection recommended by the manufacturer:
  - Refer to "5-3 Packaging, Sterilizing, Drying and Storage (Motor)"
- Degree of protection against ingress of water as detailed in the current edition of IEC 60529:
  - Control Unit: IPX0 (Not protected)
- Degree of safety of application in the presence of a flammable anesthetic mixture with air or with oxygen or nitrous oxide:
  - Equipment NOT suitable for use in the presence of a flammable anesthetic mixture with air or with oxygen or nitrous oxide.
- Mode of operation:
  - Intermittent operation ( ON:3 min, OFF:10min.)

## 2 Components

### 2-1 List of components

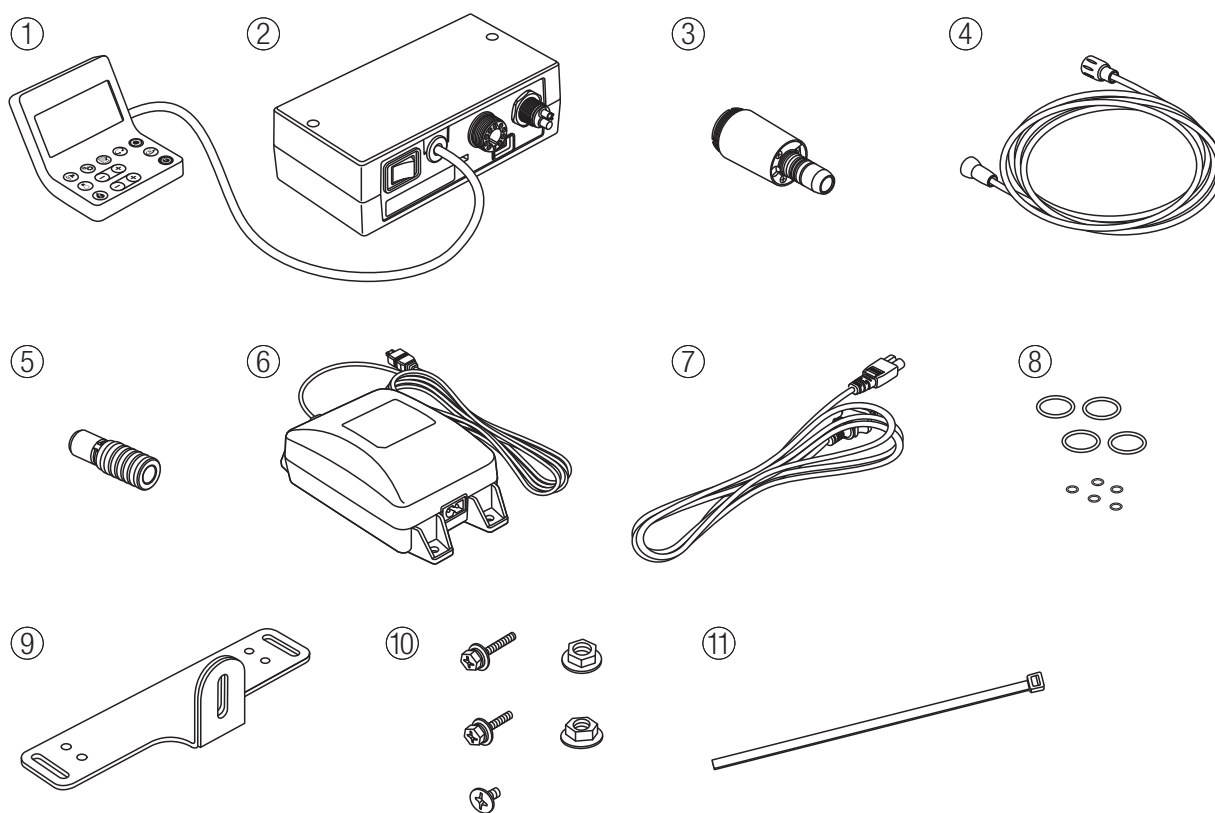

No.	Part Name	Quantity	Remark
1	Control unit	1	The control unit and the main unit are connected via the link cable.
2	Main unit	1	
3	Motor	1	-
4	Motor cord	1	Cord length: 1.8m
5	Purge nozzle	1	For purging excess oil (compatible with ISO 3964-compliant handpieces)
6	AC adapter	1	Cord length: 5m
7	AC power cord	1	Cord length: 2m
8	O-ring set	1set	Spare parts For the motor insert joint (Black: 3pcs., Blue: 1 pc.) For the pipes at the rear side of the motor (Black: 5 small pcs.)
9	Mounting bracket	1	For the main unit
10	Mounting screws and nuts	1set	M5x30 screw (2 pcs.), M4x30 screw (2 pcs.), M4 flat head screw (2 pcs.), M5 nut (2 pcs.), M4 nut (2 pcs.)
11	Cable tie	2	For fixing the link cable



**2-2** Part Names of Control Unit and Main Unit

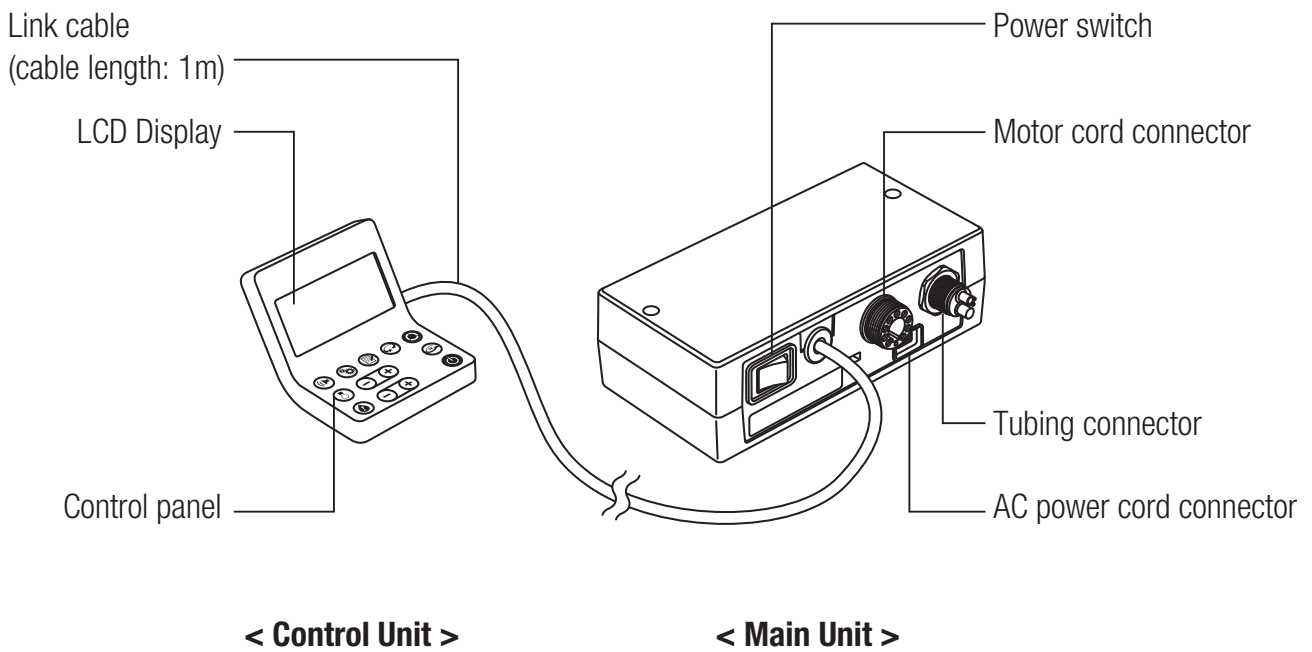

LCD Display and the Control Panel of the Control Unit



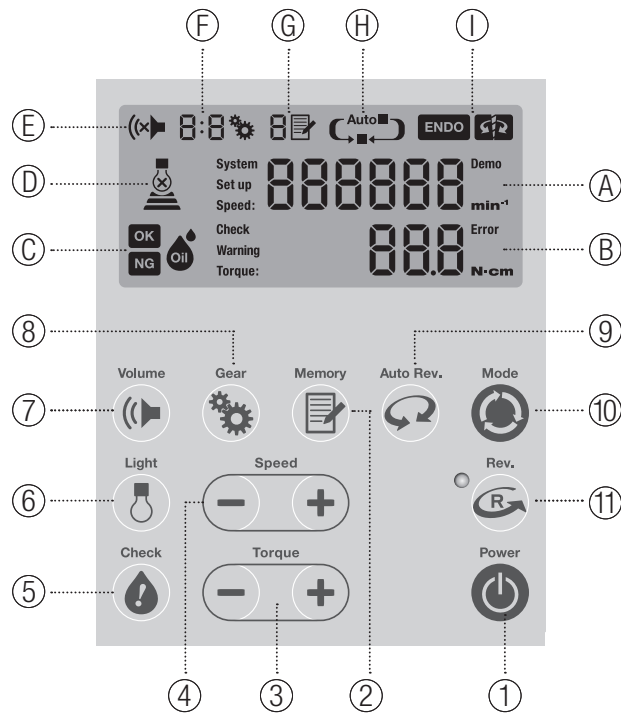

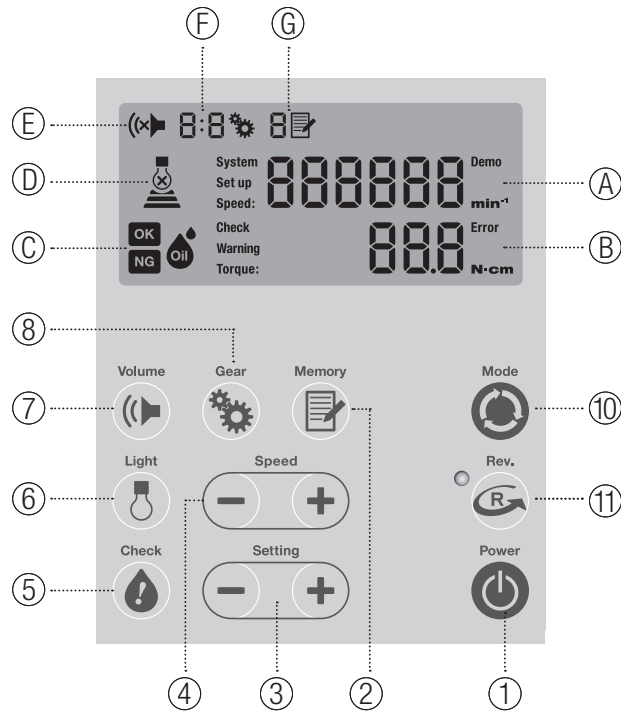

< NLZ E >









< NLZ >



## Components

No.	Key	Name	Display	Function												
①	<p>Power</p> 	Power Key	-	Press once to turn ON the power. When the power is ON, hold it down for more than two seconds to turn OFF the power												
②	<p>Memory</p> 	Memory Key	Ⓒ	<p>In General Application Mode: Motor speed can be adjusted between 100 and 40,000 min<sup>-1</sup>.</p> <p>In Rotary Endo Mode: Motor speed can be adjusted between 100 and 6,000 min<sup>-1</sup>. *Display value changes interlocked with the gear ratio.</p>												
③	<p>Torque</p> 	Torque Key (NLZ E)	Ⓓ	<p>When gear ratio is set by each time pressing this key you can adjust the torque.</p> <p>Rotary Endo Mode</p> <table border="1"> <thead> <tr> <th>Gear Ratio</th> <th>Torque Range (N·cm)</th> <th>Increment (N·cm)</th> </tr> </thead> <tbody> <tr> <td>1:1</td> <td>0.3 - 3.0</td> <td>0.1</td> </tr> <tr> <td>4:1</td> <td>0.8 - 6.0</td> <td>0.4</td> </tr> <tr> <td>6:1</td> <td>1.0 - 6.0</td> <td>1.0 - 1.2:0.2 1.2 - 6.0:0.6</td> </tr> </tbody> </table>	Gear Ratio	Torque Range (N·cm)	Increment (N·cm)	1:1	0.3 - 3.0	0.1	4:1	0.8 - 6.0	0.4	6:1	1.0 - 6.0	1.0 - 1.2:0.2 1.2 - 6.0:0.6
	Gear Ratio	Torque Range (N·cm)	Increment (N·cm)													
1:1	0.3 - 3.0	0.1														
4:1	0.8 - 6.0	0.4														
6:1	1.0 - 6.0	1.0 - 1.2:0.2 1.2 - 6.0:0.6														
	<p>Setting</p> 	Setting Key (NLZ)	-	Change the setting as described in “3-10 Changing the settings for various functions”												
④	<p>Speed</p> 	Speed Key	Ⓐ	<p>In General Application Mode: Motor speed can be adjusted between 100 and 40,000 min<sup>-1</sup>.</p> <p>In Rotary Endo Mode: Motor speed can be adjusted between 100 and 6,000 min<sup>-1</sup>. *Display value changes interlocked with the gear ratio.</p>												
⑤	<p>Check</p> 	Check Key	Ⓒ	Check the status of the handpiece as described in “4-4 Contra-Check Function”												
⑥	<p>Light</p> 	Light Key	Ⓓ	<p>Set light intensity (Strong·Moderate·Weak·OFF) By each time pressing this key you can change the volume from OFF -&gt; intensity 1 -&gt; intensity 2 -&gt; intensity 3 and then back to OFF again * The light can be turned on for 5 seconds by pressing the key while the motor is stopped.</p>												

No.	Key	Name	Display	Function
⑦	<p>Volume</p> 	Volume Key	Ⓔ	<p>Set the volume of the notifying sound generated when reaching a set torque limit value or when errors occur (High-Low·OFF)</p> <p>By each time pressing this key you can change the volume from OFF -&gt; volume 1 -&gt; volume 2 and then back to OFF again</p> <p>⚠CAUTION When the volume is set to OFF, there will be no alarm sound. Care should be taken when using the system with the volume set to OFF.</p>
⑧	<p>Gear</p> 	Gear Key	Ⓕ	<p>By each time pressing this key you can switch the gear ratio</p> <p>from 1:5 -&gt; 1:1 -&gt; 4:1 -&gt; 6:1 -&gt; and then back to 1:5 again – in General Application Mode</p> <p>from 1:1 -&gt; 4:1 -&gt; 6:1 -&gt; and then back to 1:1 again – in Rotary Endo Mode</p>
⑨	<p>Auto Rev.</p> 	<p>Auto Rev. Key (NLZ E)</p> <p>*Rotary Endo Mode Only</p>	Ⓖ	<p>By each time pressing this key you can switch the mode between AUTO STOP -&gt; AUTO REVERSE STOP -&gt; AUTO REVERSE FORWARD and then back to AUTO STOP again</p> <p style="text-align: center;">  </p> <p style="text-align: center;"> <span>AUTO STOP</span>                      <span>AUTO REVERSE STOP</span>                      <span>AUTO REVERSE FORWARD</span> </p>
⑩	<p>Mode</p> 	<p>Mode Key (NLZ E)</p>	Ⓗ	<p>Toggles between 3 application modes as below</p> <p>General                      Rotary Endo                      Reciprocating Endo Mode: Application Mode:      Mode:</p> <p>No display                      <b>ENDO</b>                      <b>ENDO</b> </p>
		<p>Setting Mode Key (NLZ)</p>		-
⑪	<p>Rev.</p> 	Rev. Key	-	<p>The rotation direction can be changed by this key. The LED lights up during reverse rotation.</p>

### 3 Preparations for Use

#### ⚠ CAUTION

Make sure that each part is properly connected. Improper connections might cause faulty operation, LED lighting failure and water or air leakage.

#### 3-1 Installing the Main Unit and the Control Unit

- 1** Fix the main unit to the dental unit using the screws. As shown below:

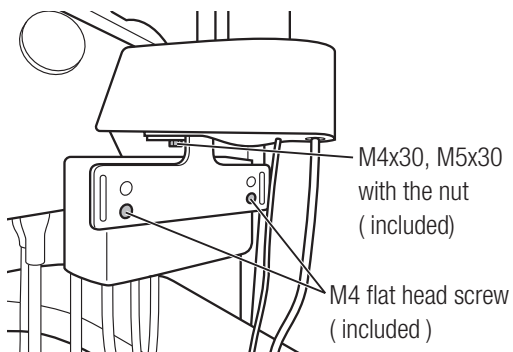

- 2** Place the control unit on the tray of the dental unit.

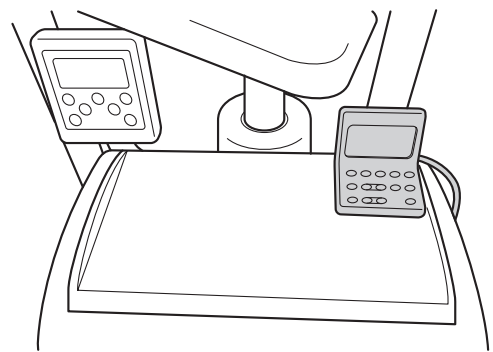

- 3** Bundle the link cable appropriately and fix it by cable tie.

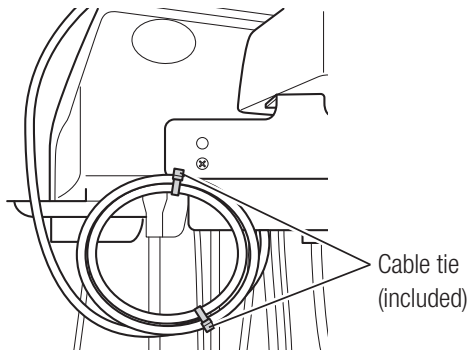

- 4** If you wish to install as shown below, optional parts are available for purchase. (Refer to "9-3 Optional Parts List")

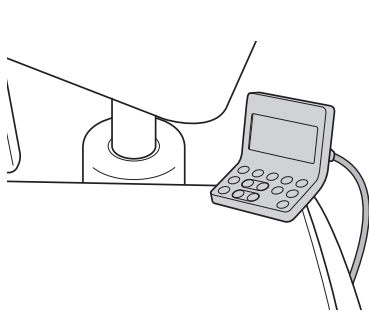

Installation example using  
NLZ STAY

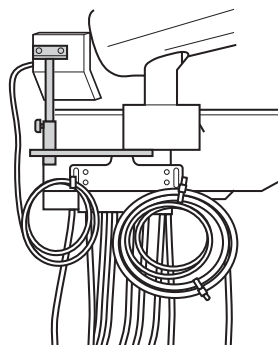

Installation example using  
NLZ MOUNTING PLATE

**⚠ CAUTION**

- Keep the main unit away from water.
- The control unit incorporates a LCD panel. Place the unit where the operator can see the display.
- Do not bend the tubing forcibly when putting the main unit in place. Allow some extra space for tubing to avoid pinching or bending it.

**3-2 Connecting the Tubing**

Align the tubing from the dental unit and the tubing connector at the back of the main unit (①). Insert it firmly and tighten it completely (②).

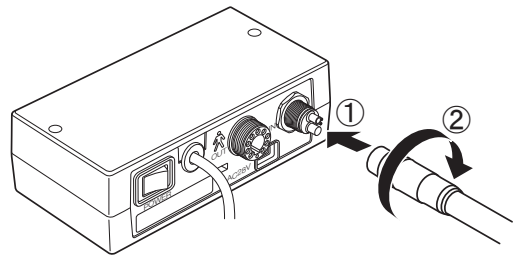
**⚠ CAUTION**

- Be sure that there is no air or water coming from tubing when attaching it to the main unit.
- Use moisture- and dust-free air as the supply air. Mixing in of moisture might cause malfunction or heat generation.
- Screw the nut properly without unnatural force, when you plug in tubing connector and motor cord connector. Avoid cross threading.
- Connect only ISO 9168-compliant, Type 2 (Midwest 4 holes), or Type 3 (ISO-compliant standard 4 holes with light) tubing.
- Air requirement: dry, free from contamination and oil. Use a compressor with a dry air system. Install an air filter if necessary. Blow out the lines before installation.
- Do not pull the tubing using more than necessary force.
- Make sure to supply coolant air. Otherwise, the motor/handpiece surface might reach a temperature of 51°C or higher.

### 3-3 Connecting the Motor Cord

Align the motor cord plug and the motor connector at the back of the main unit (①). Insert it firmly and tighten it completely (②).

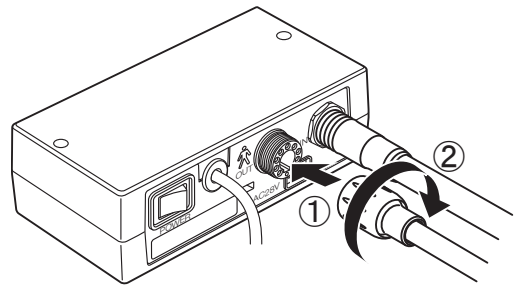

#### ⚠ CAUTION

- Gently screw in the nut of the motor cord plug when tightening it.
- Do not pull the motor cord using more than necessary force.

### 3-4 Connecting the AC Adapter

1 Check that main power switch is off. (○ side)

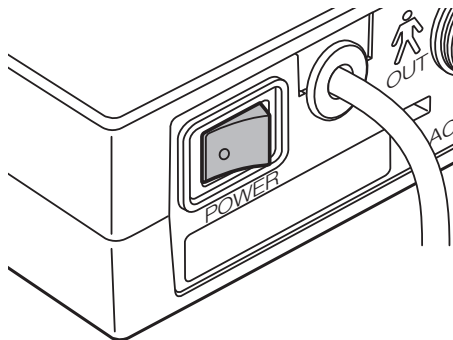

2 Insert the AC adapter plug, with the arrow facing up, into the AC power cord connector at the back of the main unit firmly.

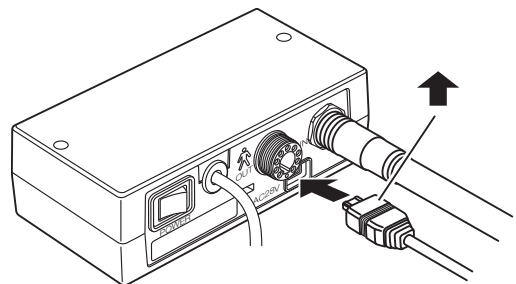

### 3-5 Connecting the AC Power Cord

**1** Insert the AC power cord into the inlet of the AC adapter.

**2** Insert the AC power cord plug to commercial power supply outlet.

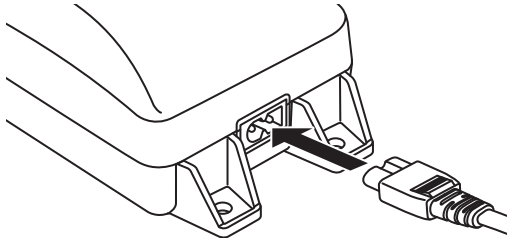

#### ⚠ CAUTION

- During this procedure the power switch of the main unit should remain OFF.
- The AC power cord included with the product has the length of 2 meters. Bundle and fix the extra cord to prevent the operator or the patient from inadvertently stepping on it.
- Use only the AC adapter, AC power cord provided with the product. Never use other AC adapters. Doing so might cause a malfunction.
- When disconnecting the AC power cord, motor cord or other cords, hold the cords by their plug and pull the plug out. Holding and pulling the cord might snap the wiring in the cord and cause a malfunction.

### 3-6 Connecting / disconnecting the motor and motor Cord

#### <Connecting>

Align and insert the pins of the connector carefully and firmly into the pin holes of the motor, and fasten the motor nut securely.

#### <Disconnecting>

Unscrew and detach the motor cord nut, and gently pull out the motor cord.

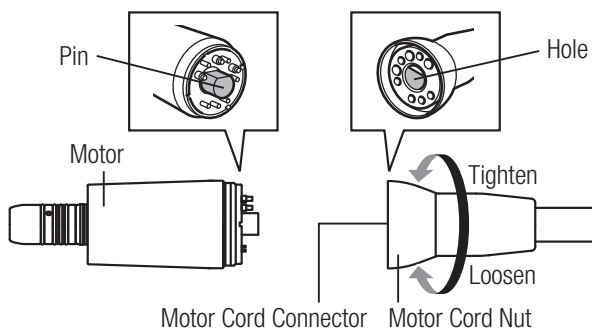



### 3-7 Using barrier sleeve (motor cord)

Use a disposable barrier sleeve that meets the local regulation for a motor cord, in order to prevent cross contamination between each patient.

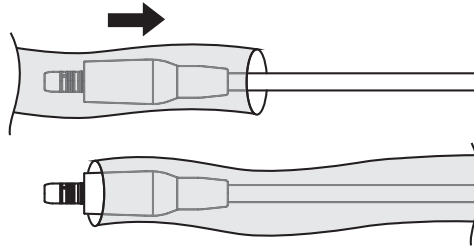

A barrier sleeve with a diameter larger than the diameter of the motor ( $\phi 22\text{mm}$ ) is recommended.

#### **⚠ CAUTION**

- Dispose of sleeves after each patient.
- Refer to the instruction of the barrier sleeve for detail.

### 3-8 Using barrier film (control unit)

Use a disposable barrier film that meets the local regulation on the surface where you touch, such as keys of the control unit, in order to prevent cross contamination between each patient.



A barrier film with a width of 5cm or more is recommended.

#### **⚠ CAUTION**

- Dispose of film after each patient.
- For prevention of erroneous operation, do not use such film as decreases the visibility.
- Refer to the instruction of the barrier film for detail.

### 3-9 Connecting / disconnecting the motor and the handpiece (option)

#### <Connecting>

- 1 Insert the E-type handpiece into the motor insert, and turn until it clicks as the positioning pin on the handpiece falls into positioning hole on the motor.
- 2 Confirm that the handpiece is securely connected to the motor.

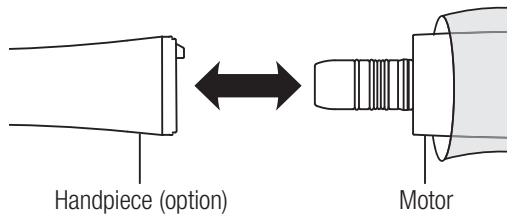

#### <Disconnecting>

Simply pull out the handpiece from the motor.

#### ⚠ CAUTION

- Ensure that the motor has completely stopped rotating before handling. Connecting or disconnecting the handpiece while the motor is rotating may result in injuries or damage the handpiece.
- Be sure to adjust the rotation speed of the motor within the allowable rotation speed of the handpiece (option).
- Lubricated handpiece should stand and allow oil to drain prior to steam sterilization cycle. Attach to the motor after the excess oil has been completely drained. If the oil enters the motor, it may cause malfunction of the motor.
- After lubrication, keep the handpiece standing apart from the motor. Connect the handpiece to the motor when using.
- Do not allow water to enter the motor. It may cause malfunction of the motor.
- Before each use, operate the motor outside the patient's oral cavity. If any abnormality, such as vibration, noise or overheating occurs, stop using the product immediately and contact your Authorized NSK Dealer. (Refer to "3-11 Check before treatment")

### 3-10 Changing the settings for various functions

Settings for various functions can be changed from their default values. This is to make the system easier to use, when it is used for the first time after purchase. You will need to enter into the setup mode, change the settings and save the new ones as below:

- 1 Turn ON ( I side ) the power switch on the main unit.

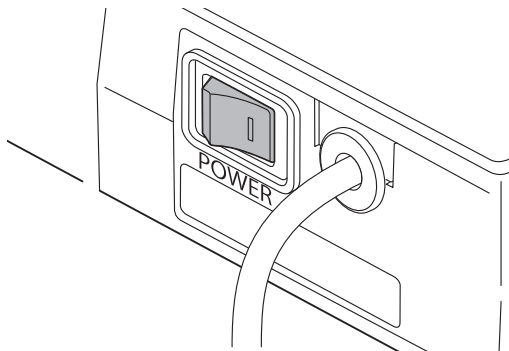

- 2 Press the Power Key on the control unit.

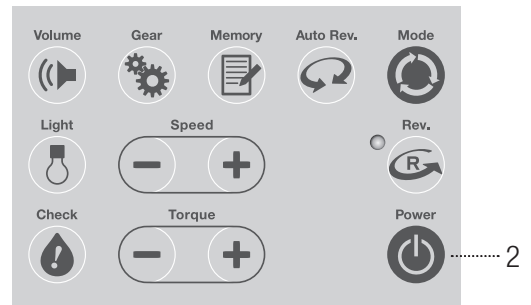

- 3 Hold down the Mode Key\* for more than two seconds. With an alarm sound, "System" and "Setup" on the LCD display will start blinking and the system will enter into the setup mode.

\* The Setting Mode Key in case of NLZ

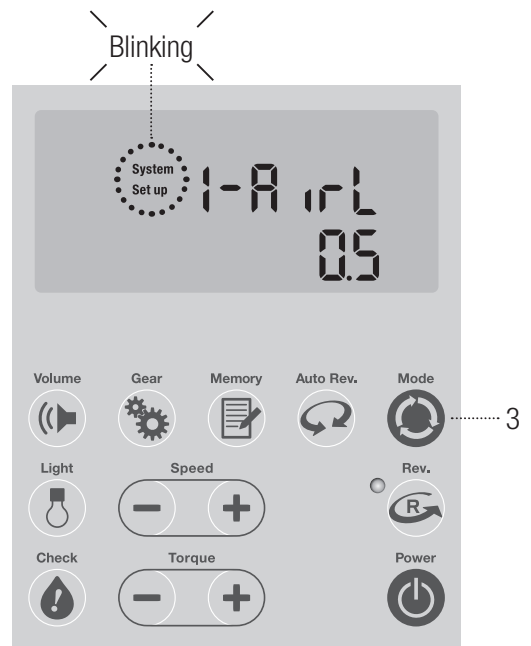

- 4** In the setup mode, the function item can be selected using the Speed Key (+/-) (①), and the value can be changed using the Torque Key (+/-)\* (②).

\* The Setting Key (+/-) in case of NLZ

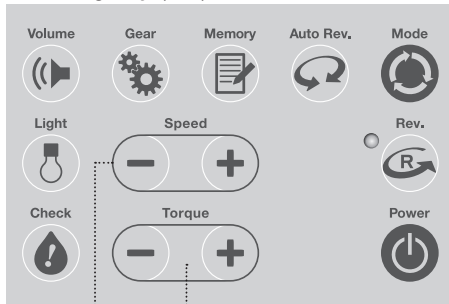

4-① 4-②

- 5** Once a value is changed, the new value will blink. Press the Mode Key quickly to save the new value. Once saved, this new value will stop blinking.

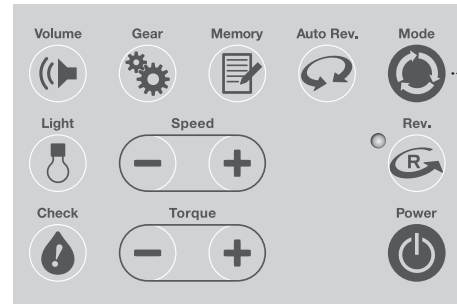

- 6** Change the settings by pressing the Torque Key (+/-). \* The Setting Key (+/-) in case of NLZ

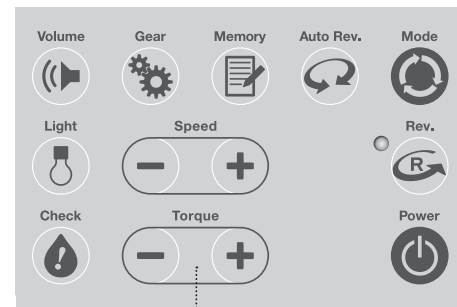

6

## Preparations for Use

<Setting each function item>

Display	Function item		Factory Setting	Setting Range
1-A rL	Foot Air Calibration: This function enables you to use the maximum speed 40,000 min-1, even though the air pressure of the dental unit is not high enough, by setting air pressures for “motor startup speed” and “maximum motor speed”.	Air pressure for motor startup speed: This is the lower limit of the air pressure at which the motor starts to operate.	0.5bar (0.05MPa)	0.3 – 3.0bar (0.03 - 0.3MPa) (@ 0.1bar increments)
2-A rH		Air pressure for maximum motor speed: This is the upper limit of the air pressure at which the motor will run at its maximum speed. This value can be set only when there is an air supply at a pressure of equal or higher than 1.5bar.	1.8bar (0.18MPa)	1.5 - 3.0bar (0.15 - 0.3MPa) (@ 0.1bar increments)
3-4HAG	Delay time for the light: This function sets the delay time for the white illumination lamp going off after the motor stops.		3 seconds	0 - 10 seconds (@ 1sec. increments)
5-REY	The notifying sound : This function sets the volume for the operation tone when a key is pressed.		High=2	High=2 Low=1 OFF=0
6-Cont	Contra-Restriction: This function automatically slows down and stops the rotation of the motor when the checking result through Contra-Check is either “OIL” or “NG”. The motor cannot be activated when the checking result is “NG” blinking which shows the status of handpiece defect. (Refer to “4-4 Contra-Check Function” and “4-8 Overheat Prevention”)		ON=1	ON=1 OFF=0
7-SAFE	Contra-SAFE: This is a function to stop the rotation of the motor when continuous motor high-load current is detected with a 1:5 increasing handpiece.* In this mode, there are selectable three sensitivity levels: Fast, standard and Slow and the “Fast” setting offers the most sensitive response. (Refer to “4-8 Overheat Prevention”) *Use NSK handpieces : the model of Z95L, Z85L, X95EX, X95L, X95, M95L, M95, X85L, X85 of 1:5 Gear Ratio.		Standard=2	Fast=3 Standard=2 Slow=1 No stop=0

**⚠ WARNING**

NSK recommends to always activate both functions of "Contra-Restriction" and "Contra-SAFE" because using these functions under "Off" or "No stop" may increase the probability or severity of overheating of defective or poorly maintained handpieces.

**NOTICE**

Set the lower air pressure limit at motor start-up, lower than the upper air pressure limit at maximum rotation of the motor.

- 7** After you are finished making changes, hold down the Mode Key again for more than two seconds to return to the regular screen.

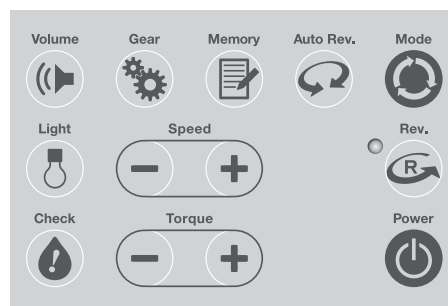

**NOTICE**

Notifying sound will not be generated when the sound volume is set to OFF. Be aware of this while using the system when the sound volume setting is OFF.

<Notifying sound during key operation>

Items	Notifying sound
When turning on the power	1 short beep
When turning off the power	1 short beep followed by 1 long beep
When pressing the keys	1 short beep
When pressing and holding the Speed Key/Torque Key	1 short beep followed by successive short beeps while the key is being pressed.
When reaching upper/ lower setting limit, when becoming inoperable	3 short beeps
When switching to the function setting mode	1 long beep
When storing into the memory	2 short beeps

### 3-11 Check before treatment

- Before each use, operate the motor outside the patient's oral cavity.
- Make sure the light is working properly and there is enough water spray.

#### CAUTION

If any abnormality, such as vibration, noise or overheating occurs, stop using the product immediately and contact your Authorized NSK Dealer.

## 4 Operation Procedure

Refer to “2-2 Part Names of Control Unit and Main Unit”, which explains the functions of the system in detail. To start operation, insert the power cord plug into an outlet and turn ON the equipment. The LCD Display will light. This product has two power control functions. The "Power Key" on the control panel and the "Power Switch" on the main unit. Use the "Power Key" to turn ON/OFF the power on a daily basis. Use the "Power Switch" to turn OFF the power when the equipment is not being used for a long period of time or when the equipment is malfunctioning.

### <Mode explanation>

Both NLZ Motor Set and NLZ E Motor Set provide general application mode which is used for dental restoration and prophylaxis. In this mode, the rotation speed can be adjusted.

The “Rotary Endo Mode” and “Reciprocating Endo Mode” are used for the endodontic procedure, which are provided only under NLZ E Motor Set.

Rotary endo mode provides low rotation speed for use with gear ratio 1:1, 4:1, and 6:1 handpieces. The value of rotation speed and torque can be adjusted.

(Refer to “4-2 Rotary Endo Mode (NLZ E Only) <Auto Reverse Function>”)

Pressing the “Check” key to perform “Contra-Check” Function before use, the status of a handpiece can be evaluated as “OK”, “OIL”, “NG” or “NG Blinking”. When the handpiece is evaluated “OK”, the Contra-Check Function works as a torque calibration. (Refer to “4-4 Contra-Check Function”)

Under the reciprocating endo mode, automatic unequal bidirectional rotation is provided. The user can not alter the preset parameters.

### <Mode selection>

System	General Mode	Rotary Endo Mode	Reciprocating Endo Mode
NLZ Motor Set	✓	Not Available	Not Available
NLZ E Motor Set	✓	✓	✓ *

\*The “Reciprocating Endo Mode” can be operated only with the NLZ Endo Contra Angle handpiece and WaveOne file. (Refer to “4-3 Reciprocating Endo Mode (NLZ E only)”)



**4-1 General Application Mode**

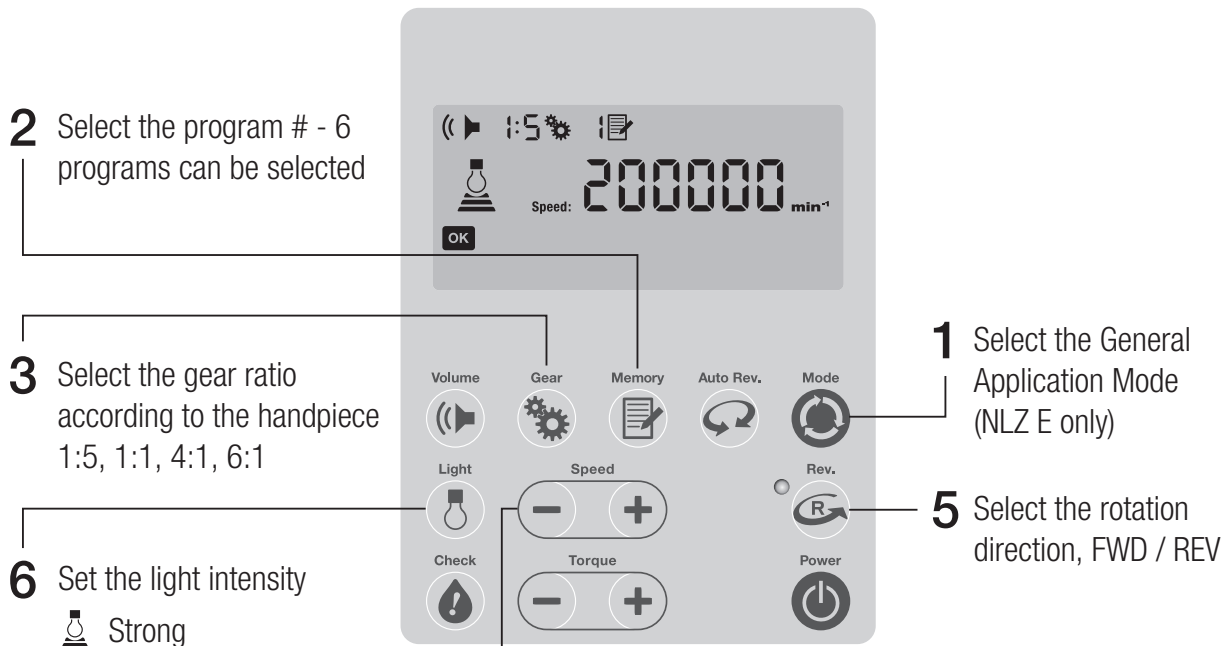

**2** Select the program # - 6 programs can be selected

**3** Select the gear ratio according to the handpiece 1:5, 1:1, 4:1, 6:1

**6** Set the light intensity

- Strong
- Moderate
- Weak
- OFF

**1** Select the General Application Mode (NLZ E only)

**5** Select the rotation direction, FWD / REV

**4** Select the proper speed required for the application

Gear Ratio	Rotation Speed (min <sup>-1</sup> )	Setting range (min <sup>-1</sup> )
1:5	500 – 200,000	20 – 100:10 Increment
1:1	100 – 40,000	100 – 1,000:100 Increment
4:1	30 – 10,000	1,000 – 5,000:500 Increment
6:1	20 – 6,600	5,000 – 50,000:1,000 Increment
		50,000 – 200,000:5,000 Increment

**NOTICE**

- Since the NLZ Endo contra angle handpiece is only for endodontic treatment, it cannot be used for General Application Mode.
- The rotation speed of the bur, mounted to the handpiece, depends on the gear ratio of the handpiece.
- The actual rotation speed is displayed during operation. The Max set speed is displayed when stopped.
- The max set speed can be adjusted even during rotation by pressing the Speed Keys on the control panel.
- When using a handpiece with the gear ratio that is not included in this product's setting, select the gear ratio setting of 1: 1. The value obtained by multiplying the displayed rotation speed by the gear ratio is the actual rotation speed.

**7** Adjust the water spray of the handpiece at the dental unit

**8** Contra-Check  
Perform Contra-Check before treatment. (Refer to “4-4 Contra-Check Function”)

**9** The motor operation will be controlled by the foot pedal of the dental unit (also called Rheostat). Pressing the pedal all the way down will run the motor up to the Max speed set at step 4

**10** Memory setting  
Press and hold the Memory Key for more than 2 seconds. After 2 short beeps the memory sign will stop blinking and gear ratio and speed will be memorized in the selected program number (M1 through M6 is shown, so that up to 6 programs can be stored in memory).

<b>NOTICE</b>
A blinking  indicates that the program is not stored in the memory yet.

**4-2 Rotary Endo Mode (NLZ E only)**

**2** Select the program # - 6 programs can be selected

**3** Select the gear ratio according to the handpiece 1:1, 4:1, 6:1

**4** Select the proper speed recommended by file manufacturers

**5** Select the proper torque recommended by file manufacturers

**6** Select the Auto-Reverse Mode: AUTO STOP / AUTO REVERSE STOP / AUTO REVERSE FORWARD

**7** Select the rotation direction, FWD / REV

**8** Set the light intensity  
Strong Moderate Weak OFF

Gear Ratio	Rotation Speed (min <sup>-1</sup> )	Setting range (min <sup>-1</sup> )
1:1	100 – 6,000	20 – 500:10 Increment
4:1	30 – 1,500	500 – 1,000:50 Increment
6:1	20 – 1,000	1,000 – 6,000:100 Increment

Gear Ratio	Torque Setting Range (N·cm)	Setting range (N·cm)
1:1	0.3 – 3.0	0.1 Increment
4:1	0.8 – 6.0	0.4 Increment
6:1	1.0 – 6.0	1.0 – 1.2:0.2 Increment 1.2 – 6.0:0.6 Increment

### NOTICE

- The rotation speed of the file, mounted to the handpiece, depends on the gear ratio of the handpiece.
- The actual rotation speed is displayed during operation. The Max set speed is displayed when stopped.
- The max set speed can be adjusted even during rotation by pressing the Speed Keys on the control panel.
- When using a handpiece with the gear ratio that is not included in this product's setting, select the gear ratio setting of 1: 1. The value obtained by multiplying the displayed rotation speed by the gear ratio is the actual rotation speed.

**9** Adjust the water spray of the handpiece at the dental unit  
Turn off the water flow of the dental unit due to lack of water flow circuit inside the NLZ Endo contra angle handpiece.

**10** Contra-Check  
Perform Contra-Check before treatment. (Refer to "4-4 Contra-Check Function")

### NOTICE

Depends on the connected contra-angle handpiece, a short beep sound may occur when the rotation starts, which is not a malfunction.

**11** The motor operation will be controlled by the foot pedal of the dental unit (also called Rheostat). Pressing the pedal all the way down will run the motor up to the Max speed set at step 4

### ⚠ CAUTION

- The torque displayed in the Rotary Endo Mode varies according to the type of the handpiece or using condition. Make sure to use an NSK-manufactured handpiece and perform the Contra-Check before use. The Contra-Check will carry out torque calibration. (Refer to "4-4 Contra-Check Function")
- Using handpieces not manufactured by NSK may cause malfunction including discrepancy between set torque limit value and the actual output torque.

**12** Memory Setting  
Press and hold the Memory Key for more than 2 seconds. After 2 short beeps the memory sign  will stop blinking and gear ratio, rotation speed, torque and auto-reverse mode will be memorized in the selected program number (M1 through M6 is shown, so that up to 6 programs can be stored in memory).

### NOTICE

A blinking  indicates that the program is not stored in the memory yet.

<Auto Reverse Function>

By each time pressing the Auto Rev. Key you can switch the mode between AUTO STOP -> AUTO REVERSE STOP -> AUTO REVERSE FORWARD and then back to AUTO STOP again

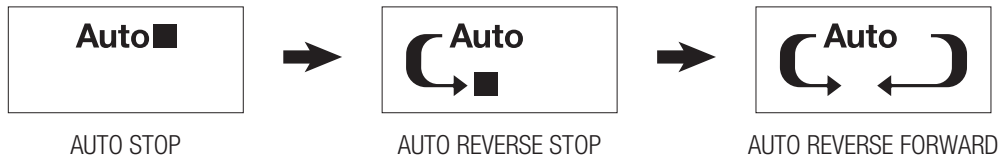

Explaining the above 3 Modes:



The handpiece starts in forward rotation. When a load reaches the set torque limit value, the motor rotation stops with a beep sound. If the load continues, the set speed on the LCD Display starts blinking until the foot pedal is released.

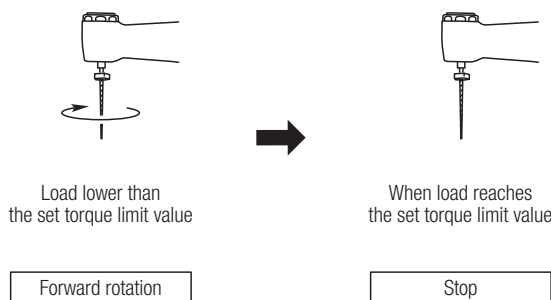

The handpiece starts in forward rotation. When a load higher than the torque limit is applied, the file will rotate in reverse with a beep sound. When the load is removed, the motor rotation stops and the set speed on the LCD Display starts blinking until the foot pedal is released. If you want the motor to rotate again, re-press the foot pedal.

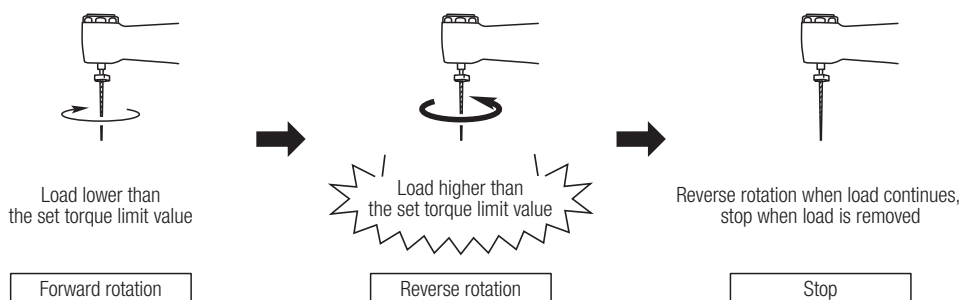



AUTO REVERSE FORWARD

The handpiece starts in forward rotation. When a load higher than the torque limit is applied, the file will rotate in reverse with a beep sound. When the load is removed, the file will return to normal rotation (forward) automatically.

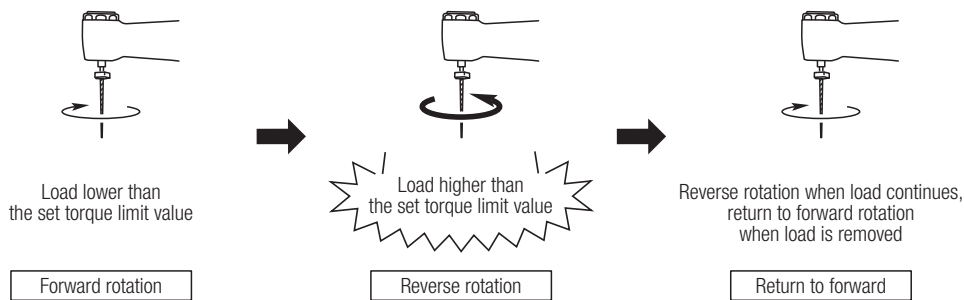

### 4-3 Reciprocating Endo Mode (NLZ E only)

The Reciprocating Endo Mode is preset for the NLZ Endo (6:1 reduction Endodontic Contra Angle Handpiece) using with the WaveOne® reciprocating file made by DENTSPLY SIRONA Group. In this mode, automatic unequal bidirectional rotation is provided and the user can not alter the preset parameters. Please use the WaveOne® Reciprocating file to operate in this mode. (WaveOne® is a registered trademark of DENTSPLY SIRONA Inc.)

- 1 Select the Reciprocating Endo Mode.
- 2 Turn off the water flow of the dental unit due to lack of water flow circuit inside the NLZ Endo contra angle handpiece.
- 3 **Contra-Check**  
Perform Contra-Check before treatment. (Refer to “4-4 Contra-Check Function”)
- 4 The motor operation will be controlled by the foot pedal of the dental unit (also called Rheostat).



Unequal bidirectional rotation

**CAUTION**

The Reciprocating Endo Mode has been designed and verified exclusively for the NLZ Endo contra angle handpiece and WaveOne® reciprocating file manufactured by DENTSPLY SIRONA Group. Using other contra angle handpieces or files may result in gear’s premature wear, overheating, or file breakage.

## 4-4 Contra-Check Function

This function evaluates the state of the Contra Angle / Straight Handpiece as:

“OK” : The check result is acceptable

“OIL” : Needs a maintenance such as lubricating with oil

“NG” : There is a serious malfunction

### WARNING

- Damaged handpiece, Foreign materials in the handpiece, Inadequate Maintenance, and Water Entrance are risks for overheating/burn event. Those abnormalities appear as vibration, noise or overheating. Check handpiece for those abnormalities before treatment, or it may cause overheating of handpiece and cause burn in patients.
- Contra-Check function neither measures the temperature of overheating handpiece directly nor assures to maintain handpiece safe temperature. As possible risk of overheating still remains even after Contra-Check, make sure to always check for above abnormalities before treatment.
- If any abnormality, such as vibration, noise or overheating occurs, stop using the handpiece immediately and contact your authorized NSK dealer.
- This function is only available for NSK Contra Angle /Straight Handpiece : models of Z95L, Z85L, X95EX, X95L, X95, M95L, M95, X85L, X85 of Gear Ratio 1:5, Z25L, X25L, X25, X65L, X65, M25L, M25, M65 of Gear Ratio 1:1, Z15L, X15L, X15, M15L, M15 of Gear Ratio 4:1 and the NLZ Endo Contra Angle Handpiece of Gear Ratio 6:1.
- Use of incorrect handpieces may cause overheating.

### NOTICE

- Perform this function before treatment to check the handpiece status.
- Contra-Check function includes torque calibration under the Rotary Endo Mode.  
Torque displayed in the Rotary Endo Mode varies according to the type of handpiece or it's using condition. This is a function to recognize the rotation torque of the attached handpiece and to adjust the generated torque into the set torque limit value.
- After the Handpiece is evaluated as “NG” or “OIL” through the Contra-Check, the motor rotation is automatically slowed down and stopped if the risk of overheating is detected. (Refer to “3-10 Changing the settings for various functions”)

## Operation Procedure

- 1 Select the Mode (NLZ E only)

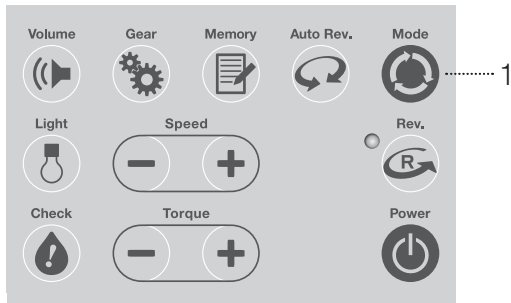

- 2 Hold down the Check Key for more than 2 seconds to start up the Contra-Check. The “GEAR” and the gear icon will start blinking after a short beep sound.

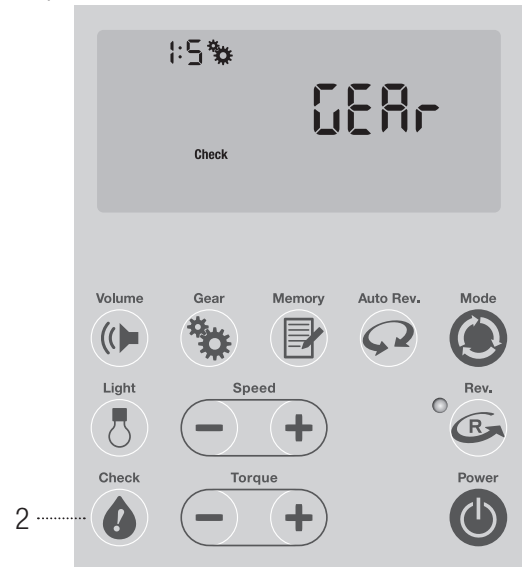

- 3 Select the gear ratio of the attached handpiece  
General Application Mode 1:5, 1:1, 4:1, 6:1  
Rotary Endo Mode 1:1, 4:1, 6:1  
Reciprocating Endo Mode 6:1 (Fixed)



### NOTICE

Make sure that the correct gear ratio of the handpiece is selected before checking process, otherwise it will lead to wrong results.

- 4 After selecting the correct gear ratio, press the Check Key again to start the checking process.



- 5 The motor automatically starts to operate at low speed and then accelerates to high speed to automatically measure the state of the handpiece.

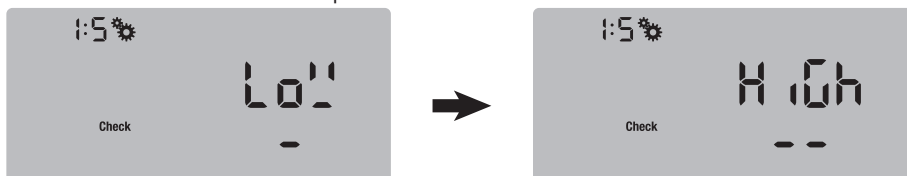

**CAUTION**

- Start the checking process while holding the handpiece. Checking, while leaving the handpiece on the handpiece stand, may cause drop and damage of the handpiece and injury to user or patient.
- To avoid any problems, care should be taken as the motor operates and rotates automatically.
- During the checking process, the system is designed to stop in an emergency by pressing any key on the control panel. So, if you sense any danger, press any key on the control panel for an emergency stop.

**NOTICE**

Checking is possible with or without a bur/file.

Refrain from using burs which are not specified in the instruction of handpiece, otherwise it will lead to wrong results.

- 6 Once the process is completed, "Fin" will be displayed on the screen after a beep sound along with the <Checking Result> displayed on the screen as one of these cases:

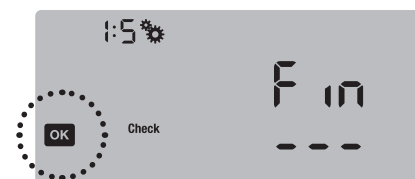



### <Checking Result>



The check result is acceptable. After use, follow maintenance procedures as instructed in the operation manual of the handpiece.

#### WARNING

If any abnormality, such as vibration, noise or overheating occurs, stop using the handpiece immediately even the display shows the check result of "OK". We recommend repair or use new handpiece. Contact your Authorized NSK Dealer.



The handpiece needs maintenance such as lubricating with oil.

#### WARNING

If you get the same result even after performing maintenance, the handpiece condition might have deteriorated. We recommend repair or use new handpiece. Contact your Authorized NSK Dealer.



The handpiece is not functional.

#### WARNING

- If you get the same result even after performing maintenance, the handpiece may be broken. We recommend repair or use new handpiece. Contact your Authorized NSK Dealer.
- Continuing to use this handpiece should cause serious injuries due to abnormal heat generation.



The handpiece is damaged and motor cannot be activated in this situation!

Blinking

#### WARNING

- When you get this result, the handpiece is broken. Stop using the handpiece and change it to other handpiece. We recommend repair or use new handpiece. Contact your Authorized NSK Dealer.
- Continuing to use this handpiece causes serious injuries due to abnormal heat generation.

- 7 Press the Check Key again to return to the regular screen.

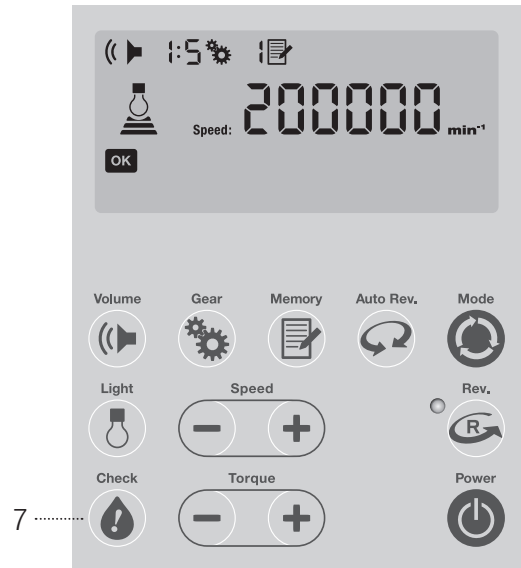

**CAUTION**

- There are cases where the motor works and the checking result is “OK” even though the bur or the file does not rotate. In such case, the gears of the handpiece are worn out and damaged. Please contact your Authorized NSK Dealer.
- Contra-Check does not guarantee safety of handpieces in any environment. Perform pre-use inspections (“3-11 Check before treatment”) together with Contra-Check to ensure safety before use.

**NOTICE**

Depending on the type of lubricator and maintenance unit, oil may build up inside the handpiece and have bad impact on the checking process. If “OIL” or “NG” is displayed:

- (1) Insert the purge nozzle (Refer to “2-1 List of components”) into the rear of the handpiece, until it clicks of a secure insertion and then insert the tip of the air gun / syringe into the purge nozzle.

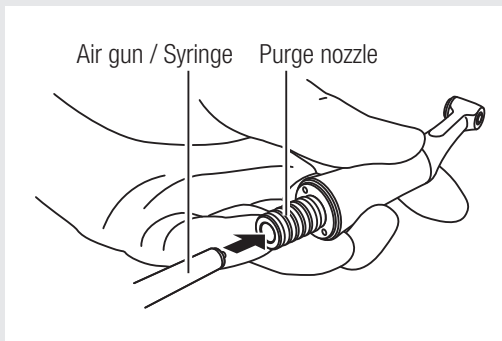

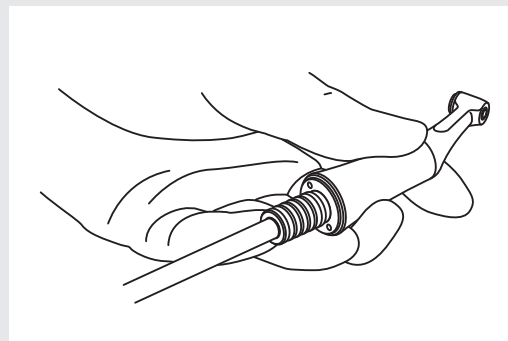

- (2) Run air with air gun / syringe for 30 seconds to purge oil from inside the handpiece.



- (3) Perform the checking again.

**4-5 Sound Volume (When the load exceeds the set torque limit value, Error etc.)**

1 Press the Volume key.

-  Volume: High
-  Volume: Low
-  Volume: OFF

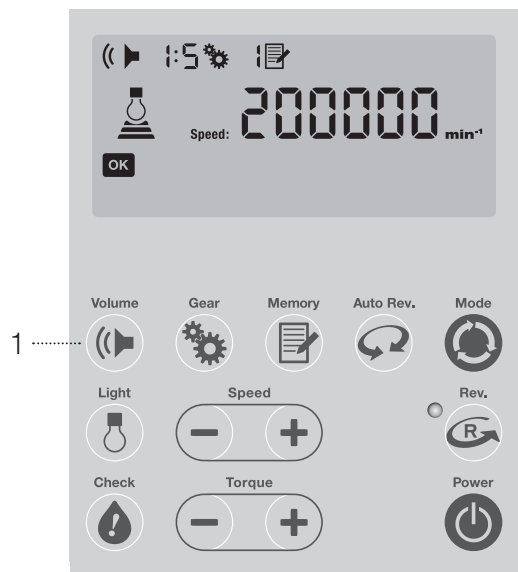

<List of Notifying Sound>

Type		Notifying Sound
Rotary Endo Mode	When reaching 75% of the torque setting	Melody 1
	When reverse rotating	Melody 2
Alarm sound for when the motor or a handpiece is overheating.		Melody 3
When the motor/ handpiece is not functional, meaning the checking result of the handpiece is "NG (blinking)" Turning ON the power while pressing the foot pedal of the dental unit		A set of 3 short beeps continues to sound.
When an error is generated:		1 short beep followed by 1 long beep.

**⚠ CAUTION**

Notifying sound will not be generated when the sound volume is set to OFF. Be aware of this while using the system with the sound volume set to OFF.

## 4-6 Last Memory Function

This function memorizes the last settings of each mode just before the power is turned OFF using the Power key.

When the power is turned back ON, this function retains those settings of each mode.

The settings stored in this memory includes:

In <General Application Mode>

Gear ratio, rotation speed, light intensity, notifying sound volume, and memory number

In <Rotary Endo Mode>

Gear ratio, rotation speed, torque, auto reverse mode, light intensity, notifying sound volume, and memory number

In <Reciprocating Endo Mode>

Notifying sound volume

## 4-7 Initializing Program (Restoring the Factory Setting)

This function allows to reset the programs of various settings (gear ratio, rotation speed, torque, auto reverse mode) stored in the memory to the default factory setting.

By carrying out this function, various functional settings (such as air pressure for motor startup speed) as described in “3-10 Changing the settings for various functions” will be reset to the default factory setting.

**1** Turn OFF the power of the control unit.

**2** While pressing down the Torque Key\* (press +/- keys simultaneously) (①), press and hold the Power Key (②) to turn ON the power. \*Setting key in case of NLZ.

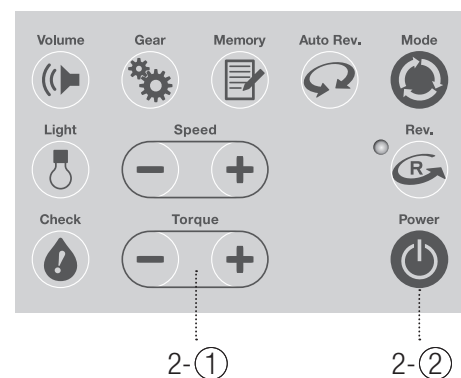
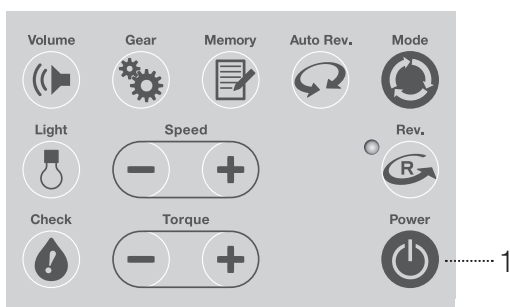

## Operation Procedure

- 3 With a short beep sound “rESEt” will be displayed on the LCD Display. Press the Mode Key.

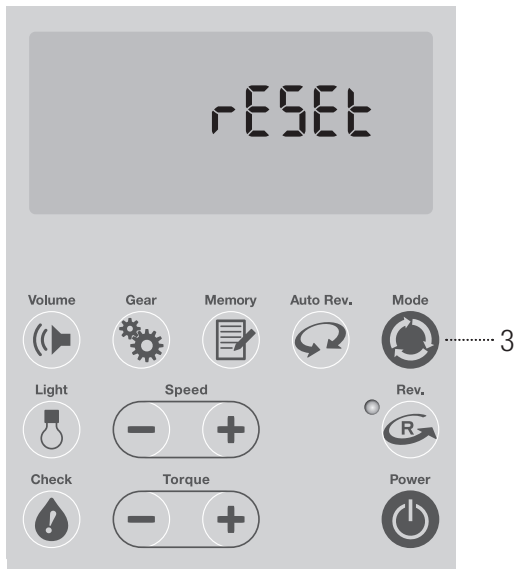

- 4 With a long beep sound followed by a short beep sound “Fin” will be displayed on the LCD Display. With another short beep sound the display will return to the last screen before the control unit was turned OFF.

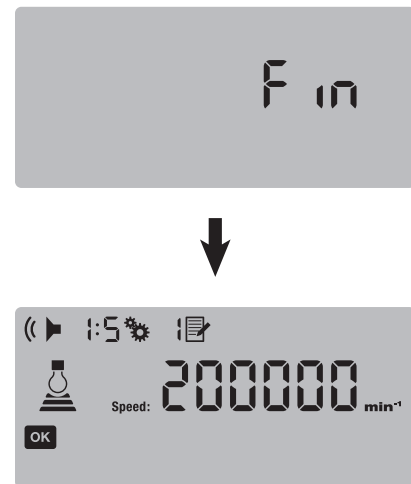

- 5 Press the Memory Key in the General Application Mode or Rotary Endo Mode. When the memory sign  stops blinking, initializing is completed.

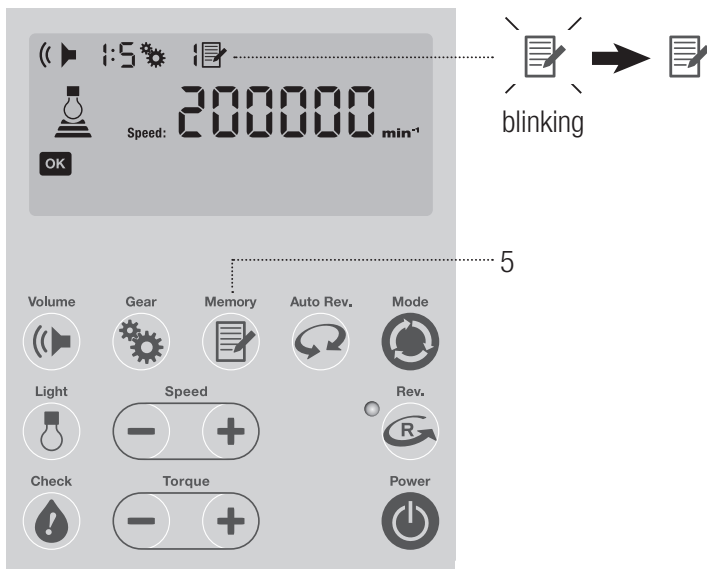

<Default Factory Setting>

Mode	Memory No.	Gear ratio	Rotation speed (min <sup>-1</sup> )	Torque (N · cm)	Auto reverse mode
General Application Mode	1	1:5	200,000		
	2	1:1	40,000		
	3	1:1	30,000		
	4	1:1	20,000		
	5	1:1	10,000		
	6	4:1	3,000		
Rotary Endo Mode	1	1:1	250	1.0	AUTO REVERSE FORWARD
	2	1:1	250	1.5	AUTO REVERSE FORWARD
	3	1:1	250	2.0	AUTO REVERSE FORWARD
	4	1:1	250	3.0	AUTO REVERSE FORWARD
	5	1:1	300	2.0	AUTO REVERSE FORWARD
	6	1:1	1,000	3.0	AUTO STOP

**NOTICE**

If necessary, take a memo of the latest settings before initializing.

**4-8 Overheat Prevention**

Following functions detect a risk of overheating from motor current and rotation speed and then slows down and stops motor rotation by activating the protection circuit to prevent incidents or failure due to the overheat of the handpiece or the motor.

<Motor Overheat Prevention Function>

This function stops the rotation of the motor when detecting overload or a risk of abnormal heating of the motor.

"Warning" and "HEO" will be displayed along with alarm sound and rotation of the motor will be slowed down.

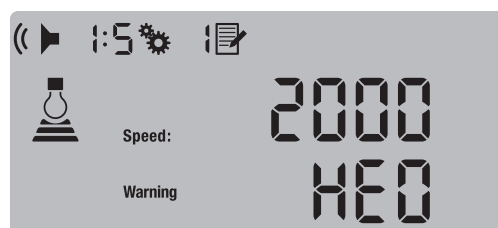

Continued use will result in motor stop and Error Code "E8" will be displayed. (Refer to "7-1 Error Code")

## Operation Procedure

### <Contra-Restriction>

This function automatically slows down and stops the rotation of the motor when the checking result through Contra-Check is either "OIL" or "NG".

"Warning" and "HE1" will be displayed along with an alarm sound and rotation of the motor will stop after approximately 2 seconds.

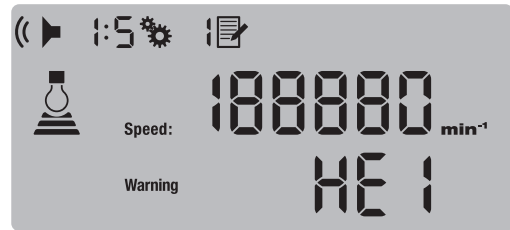

Error Code "E8" will be displayed once the motor stops. (Refer to "7-1 Error Code")

### NOTICE

Refer to "3-10 Changing the settings for various functions, Contra-Restriction". Be aware that changing the setting to "OFF" will deactivate this function.

### <Contra-SAFE>

This is a function to stop the rotation of the motor when possible risk of overheat is detected with a 1:5 increasing handpiece. Error Code "EE" will be displayed once the motor stops. (Refer to "7-1 Error Code")

### NOTICE

Refer to "3-10 Changing the settings for various functions, Contra-SAFE". Be aware that changing the setting to "No stop" will deactivate this function.

### ⚠ WARNING

- NSK recommends to always activate both functions of "Contra-Restriction" and "Contra-SAFE" because using these functions under "Off" or "No stop" may increase the probability or severity of overheating of defective or poorly maintained handpieces.
- "Contra-Restriction" and "Contra-SAFE" functions are additional features for reducing the risk of handpiece overheat but may not assure to maintain handpiece safe temperature.
- If any abnormality, such as vibration, noise or overheating occurs, stop using the handpiece immediately and contact your authorized NSK dealer.

## 5 Post-use Maintenance

### ⚠ CAUTION

- Follow local rules, regulations, and guidelines regarding the reprocessing of devices.
- Perform the following cleaning and disinfection quickly after treatment (within 1 hour) to remove any residue.
- Do not perform steam sterilization the control unit, motor cord and AC adapter, AC power cord.
- Do not lubricate the motor. It may cause overheating and product failure.
- Do not use the following fluids to wipe, immerse or clean the product; strong/super acid water, strong acid/alkaline chemicals, chlorine containing solutions, solvents such as benzene or thinner. It may cause color change of resin part, or corrosion of the metal part of the NLZ Motor System.
- Steam sterilization is recommended for the product. The validity of other sterilization methods (such as plasma sterilization or EOG sterilization) is not confirmed.
- For details on maintenance of the handpiece, check the Operation Manual of the handpiece.
- Do not immerse the product in disinfectant or perform cleaning with an ultrasonic washer. Doing so may cause product failure.

After each patient, maintain the product as follows.

### 5-1 Cleaning at point-of use (Motor)

- 1 Always wear protective gloves, a mask, and protective goggles for safety purposes and to minimize the risk of infection.

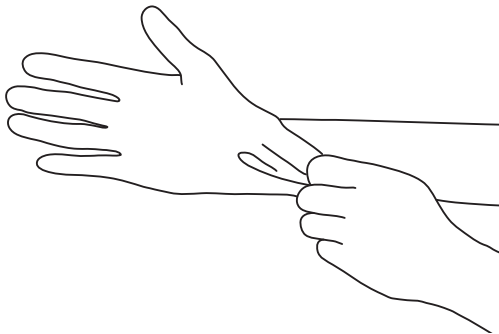

- 2 Turn off power by pressing the Power Key

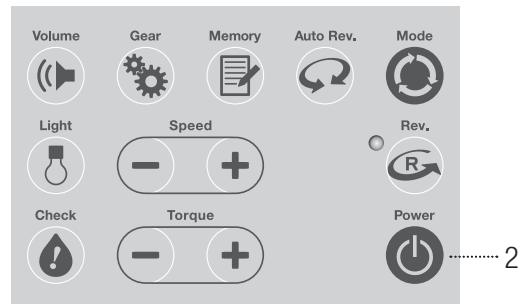

- 3 Remove the bur/file.

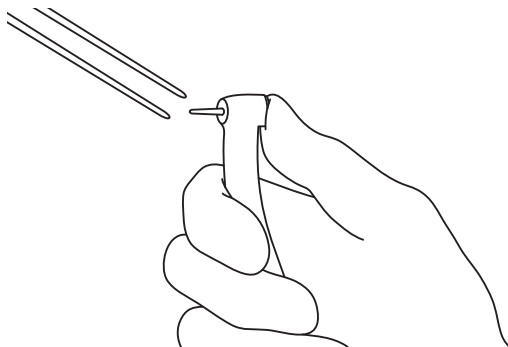



## Post-use Maintenance

---

- 4** Wipe the exterior of the motor attached with the handpiece clean using a cloth moistened with disinfectant or ethanol with a concentration of 60-90%.

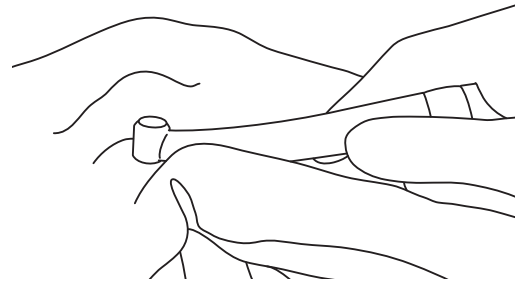

- 5** Remove the handpiece from the motor.

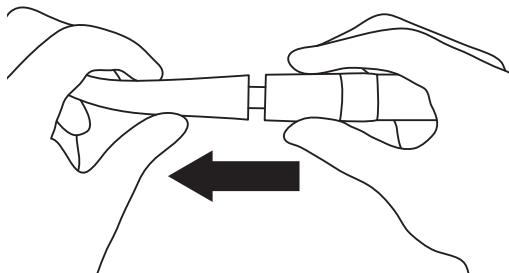

- 6** Remove the motor from the motor cord.

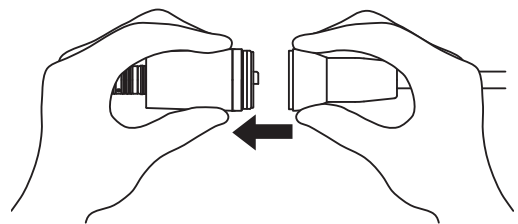

- 7** Carry the motor to the decontamination area.

### 5-2 Cleaning, Disinfecting (Motor)

Wipe the exterior of the motor clean using a cloth moistened with disinfectant or ethanol with a concentration of 60-90%.

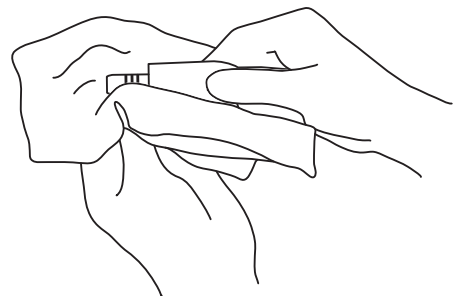

**5-3 Packaging, Sterilizing, Drying and Storage (Motor)**

- 1** Insert the motor into a sterilization pouch that conforms to ISO 11607-1, and seal the pouch.
- 2** Perform steam sterilization with the following conditions.

Type	Gravity Displacement	Pre-Vacuum (Dynamic Air Removal)
Temperature	134°C	134°C
Full Cycle Time	3 min. or longer	3 min. or longer

- 3** Store the motor in a clean location without humidity.

**⚠ CAUTION**

- Follow local rules, regulations, and guidelines regarding the reprocessing of devices.
- Immediately after sterilization is complete (within 1 hour), remove the motor from the sterilizer. Failure to do so may cause corrosion.
- Do not sterilize the control unit, main unit, AC adapter, AC power cord, motor cord.
- Do not lubricate the motor. It may cause overheating and product failure.
- Do not perform steam sterilization the product with other instruments even when it is in a pouch. This is to prevent possible discoloration and damage to the product from chemical residue on other instruments.
- Do not heat or cool the product too quickly. Rapid change in temperature could cause damage to the motor.
- To avoid product failure, do not use a sterilizer that exceeds a cycle temperature of 136°C, including the dry cycle. In some sterilizers, the chamber temperature may exceed 136°C. Contact the sterilizer manufacturer for detailed information about cycle temperatures.
- Do not touch the product immediately after steam sterilization as it will be very hot and must remain in a sterile condition.
- Steam sterilization is recommended for the product. The validity of other sterilization methods (such as plasma sterilization or EOG sterilization) is not confirmed.
- Keep the product in suitable atmospheric pressure, temperature, humidity, ventilation, and sunlight. The air should be free from dust, salt and sulphur.
- Sterility is not guaranteed after the sterility retention period specified by the manufacturer and seller of the sterilization pouch has elapsed. If the sterility retention period has elapsed, perform sterilization again with a new sterilization pouch.

**NOTICE**

NSK recommends Class B sterilizers as stated in EN 13060.

## 6 Maintenance

### 6-1 Replacing the O-rings (Motor insert)

If a deteriorated O-ring makes it difficult to attach the handpiece or causes water or air to leak, replace the O-ring.

Using a needle or other pointed tool, remove defective O-rings from the motor insert section, and fit new O-rings into the O-ring grooves.

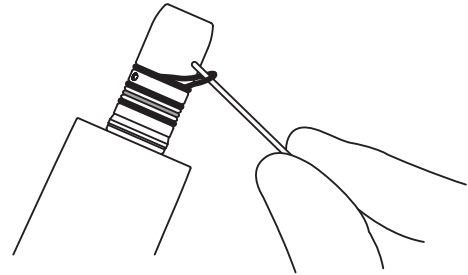

#### CAUTION

The blue O-ring is thinner than the other three O-rings. When inserting new O-rings, make sure that they are inserted in the correct grooves as shown in the figure.

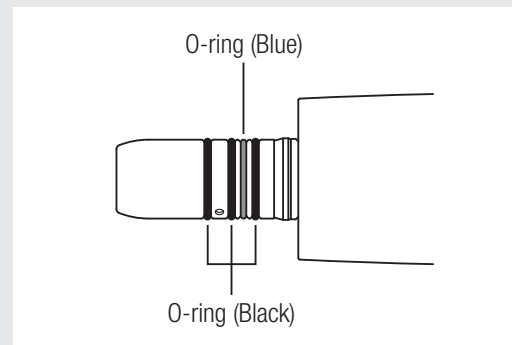

## 6-2 Replacing the O-rings (Motor rear side)

If water or air leaks from the motor and motor cord connection, replace the O-ring(s).

Using a needle or other pointed tool, remove the defective O-ring(s) from the pipe at the motor rear section, and fit new O-ring(s) into the O-ring groove(s).

(Air circuit: 2 pcs., water circuit: 2 pcs., coolant air circuit: 1 pc.)

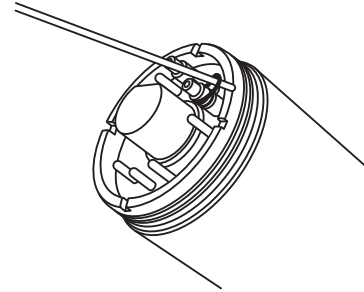

### ⚠ CAUTION

If an O-ring deteriorates, the following phenomena might occur:

- Water leakage, no water discharge
- Air leakage, no air discharge
- Generation of vibration
- Handpiece becomes difficult to attach or remove

### NOTICE

Refer to "9-2 Spare Parts List" to identify the correct parts.

## 6-3 Periodical Maintenance Checks

Every 3 months, perform periodical maintenance checks, referring to the check sheet below. If any abnormalities are found, contact your Authorized NSK Dealer.

Points to check	Details
Rotation	Rotate the motor/handpiece and check for abnormalities such as abnormal vibration, noise, and overheating.

## 7 Troubleshooting

### 7-1 Error Code

If the motor stops due to an abnormality such as a malfunction, overload, overheat, etc. it automatically checks the state of all components, detects the cause of the abnormality and displays a warning and error code on the LCD panel of the control unit.

Warning	Description of Warning	Action (Check / Remedy)
HE1	The handpiece has been used after the checking result through Contra-Check was either "OIL" or "NG".<Contra-Restriction> *	Perform maintenance of the handpiece and then check the handpiece by <Contra-Check>.
HE0	Overload or a risk of abnormal heating of the motor detected. <Motor overheat prevention function> *	Avoid overloading the handpiece with heavy cutting, etc. and wait for the warning to disappear.

\* If you continue using the product, the motor will stop and error code "E8" will be displayed.

Error Code	Description of error	Action (Check / Remedy)
E0	The motor shaft is locked.	Check if the handpiece is connected properly.
E1	Detected over current in the circuit.	Avoid overloading the handpiece with continuous heavy cutting, etc. Press the foot pedal again to remove the error.
E2	Detected a higher motor speed than the rated value.	
E3	The motor drive IC generated an error signal.	
E4	Detected high temperature of FET.	Allow the unit to cool down and try again
E5	Detected an overvoltage input to the unit.	Check proper connection of AC adaptor and AC power cord.
E6	Detected an overvoltage of an LED light.	Check the LED light connection.
E7	Detected a residual overvoltage when the motor was started.	Wait for approx. 5 sec., then press the foot pedal again. If the error does not disappear, check if the motor and motor cord are connected properly.
E8	A handpiece heat generation error was detected.	Perform maintenance of the handpiece, and then check the handpiece by the Contra- Check.
	A motor heat generation error was detected.	Leave the motor until it cools down.
E9	The motor does not start up.	Check the motor connection.
EC	Data cannot be saved to EPROM (Memory).	Turn the power OFF and then ON again.
ED	Signals from the sensor cannot be read.	Check the connection of the motor to motor cord.
EE	An increasing handpiece heat generation error was detected.	Perform maintenance of the handpiece, and then check the handpiece by the Contra- Check.
EF	Detected an under-voltage input to the unit.	Check proper connection of AC adaptor and AC power cord.

When an error code is displayed, stop operation of all devices immediately and perform the remedy indicated in the table above. If the error code appears again, turn the power OFF and then ON again and check if the error code disappears. If the error persists, the product may be broken. Contact your Authorized NSK Dealer.

## 7-2 Troubles and Actions

When trouble is found, check the following again before contacting your Authorized NSK Dealer. If none of these is applicable or the trouble is not remedied even after action has been taken, a failure of this product is suspected.

Troubles	Cause	Actions
<b>The LCD Display does not light.</b>	The power Switch is OFF.	Turn ON the power.
	The AC adapter or AC power cord is not connected correctly.	Check the connection.
	Internal Fuse is blown, due to some reason	Contact your Authorized NSK Dealer.
<b>The motor does not run.</b>	The tubing, motor cord, AC adapter or AC power cord is not connected correctly.	Check the connection.
	The air pressure is not given, or not proper from the dental unit.	Check the air pressure of the dental unit.
	The LCD Display shows an error code.	Refer to the error code. (Refer to "7-1 Error Code")
<b>The rotation speed of the motor does not rise.</b>	The air pressure of the dental unit is lower than the "Upper limit of the air pressure"	Set the Upper limit of the air pressure below the air pressure of the dental unit. (Refer to "3-10 Changing the settings for various functions")
<b>Beeps continue to sound when turning ON the switch.</b>	You are stepping on the foot pedal when turning on the power switch. (Safety function)	Do not step the foot pedal, and turn on the power switch.
<b>The LED does not light.</b>	Reached the end of life expectancy.	Contact your Authorized NSK Dealer.
<b>The motor heats up abnormally during rotation.</b>	Coolant air is not given, or not proper from the dental unit.	Check the air pressure on the side of the dental unit.
<b>Water leakage</b>	The tubing, motor cord is not connected correctly.	Check the connection. If it is happening inside the control unit, contact your Authorized NSK Dealer.
<b>Settings when the power is turned ON are different from the previous ones when turning off the power.</b>	The power is turned OFF using the main unit's power switch.	Previous settings will not be retained when turning OFF the main unit's power switch. Turn OFF using the control unit's Power Key.

## 8 Specifications

### 8-1 Specifications

#### Control Unit, Main Unit

Model	NLZ E U (NE319): Endo function available NLZ U (NE318): Endo function not available
Rated Input	AC28V 50/60 Hz
Air Pressure	4bar (0.4MPa)
Dimensions	Control Unit : W75.3 x D86.2 x H63.8 mm Main Unit: W146 x D94.2 x H48 mm Link Cable: 1.0 m

#### AC Adaptor

Model	NE180
Rated Input	AC120V 50/60Hz 41VA AC230V 50/60Hz 41VA
Rated Output	AC28V 1.3A
Fuse Rating	AC120V TR5-T C1 250V 19372 T1.6A AC230V TR5-T C1 250V 800mA
Dimensions	W100 x D178 x H64 mm

#### Motor

Model	NLZ
Rotation Speed	100 - 40,000 min <sup>-1</sup>
Max. Torque	4.2N • cm
Dimensions	Ø22 x 68.8 mm
Optic	White LED
Water Supply	65 mL/min or more
Chip Air Supply	1.5 L/min or more
Coolant Air Supply	6.5 NL/min or more

	Temperature	Humidity	Pressure
Use Environment	10 - 40°C	30 - 75%*	-
Transportation and Store Environment	-10 - 50°C	10 - 85%*	500 – 1,060hPa

\*No Condensation

**8-2** **Symbol**



This product can be sterilized in a steam sterilizer up to Max. 135°C.



Conforms to CE European Directive of "Medical device directive 93/42/EEC."



Manufacturer.



TUV Rhineland of North America is a Nationally Recognized Testing Laboratory (NRTL) in the United States and is accredited by the Standards Council of Canada to certify electro-medical products with Canadian National Standards



Consult operation instructions



Class II equipment



Type B applied part



Caution, consult accompanying documents



Follow the waste of electric and electronic equipment (WEEE) Directive (2012/19/EU) for product and accessory disposal



Marking on the outside of Equipment or Equipment parts that include RF transmitters or that apply RF electromagnetic energy for diagnosis or treatment.



Serial number



GS1 DataMatrix for Unique Device Identifier.



## 9 After-sales Service

### 9-1 Warranty

NSK products are warranted against defects in manufacturing, workmanship and materials. NSK reserves the right to analyze and determine the cause of any problem. Warranty is voided should the product not be used in accordance with this manual or has been tampered with by unqualified personnel or has had non NSK parts installed. Replacement parts are available for seven years beyond discontinuation of the model.

### 9-2 Spare Parts List

Model	Order Code	Remarks
O-ring Set	Y1003728	For the motor insert section (Black: 3pcs., Blue:1 pc.)
O-ring	D0312010050	For the motor rear side
NLZ	E1152051	Motor (without a motor cord)
NLZ CD	E1152061	Motor cord (1.8m)
Purge Nozzle	Z1259080	-
NLAC (120V)	Y141133	AC adapter (common with NLX nano)
NLAC (230V)	Y141135	
AC Power Cord	U438550	120V
AC Power Cord	U439550	230V
NLZ U BRACKET	Z1322	A bracket used for mounting to the main unit.
NLZ E U	U1142002	NLZ E control unit, main unit
NLZ U	U1141002	NLZ control unit, main unit

**9-3 Option Parts List**

Model	Order Code	Remarks
NLZ Endo	C1130	6:1 Reduction Endodontic Contra Angle Handpiece
NLZ STAY	Z1321	A stay used for mounting to the control unit.
NLZ MOUNTING PLATE	Z1323	A plate used for mounting to the control unit.
NLZ CDL	E1152062	Motor cord (2.2m)

**9-4 Disposing product**

In order to avoid the health risks of operators handling the disposal of medical equipment, as well as the risks of environmental contamination caused thereof, a surgeon or a dentist is required to confirm the equipment is sterile. Ask specialist firms who are licensed to dispose of specially controlled industrial wastes, to dispose the product for you.

## 10 EMC Information (Electromagnetic Compatibility Information)

Guidance and manufacturer's declaration - Electromagnetic Emissions		
The product is intended for use in the electromagnetic environment specified below. The customer or the user of the product should assure that it is used in such an environment.		
Emissions test	Compliance	Electromagnetic environment – guidance
RF emissions CISPR11/EN55011	Group 1	The product uses RF energy only for its internal function. Therefore, its RF emissions are very low and are not likely to cause any interference in nearby electronic equipment.
RF emissions CISPR11/EN55011	Class B	The product is suitable for use in all establishments, including domestic establishments and those directly connected to the public low-voltage power supply network that supplies buildings used for domestic purposes. (*).This applies to the AC230V system. For AC120V system, this is "Not applicable".
Harmonic emissions EN/IEC61000-3-2	Class A	
Voltage fluctuations/flicker emissions EN/IEC61000-3-3	Complies	

Guidance and manufacturer's declaration - Electromagnetic Immunity			
The product is intended for use in the electromagnetic environment specified below. The customer or the user of the product should assure that it is used in such an environment.			
Immunity test	IEC/EN60601 test level	Compliance level	Electromagnetic environment - guidance
Electrostatic discharge(ESD) EN/IEC61000-4-2	±(2,4)6kV contact ±(2,4)8kV air	±(2,4)6kV contact ±(2,4)8kV air	Floors should be wood, concrete or ceramic tile. If floors are covered with synthetic material, the relative humidity should be at least 30%.
Electrical fast transient/burst EN/IEC61000-4-4	±2kV for power supply lines ±1kV for input/output lines	±2kV for power supply lines ±1kV for input/output lines	Mains power quality should be that of a typical commercial or hospital environment.
Surge EN/IEC61000-4-5	±1kV line(s) to line(s) ±2kV line(s) to earth	±1kV line(s) to line(s) ±2kV line(s) to earth	Mains power quality should be that of a typical commercial or hospital environment.
Voltage dips, short interruptions and voltage variations on power supply input lines EN/IEC61000-4-11	<5% Ut (>95% dip in Ut) for 0.5 cycles 40% Ut (60% dip in Ut) for 5 cycles 70% Ut (30% dip in Ut) for 0.5 cycles <5% Ut (<95% dip in Ut) for 5 sec	<5% Ut (>95% dip in Ut) for 0.5 cycles 40% Ut (60% dip in Ut) for 5 cycles 70% Ut (30% dip in Ut) for 0.5 cycles <5% Ut (<95% dip in Ut) for 5 sec	Mains power quality should be that of a typical commercial or hospital environment. If the user of the product requires continued operation during power mains interruptions, it is recommended that the product be powered from an uninterruptible power supply or a battery.
Power frequency (50/60Hz) magnetic field EN/IEC61000-4-8	3 A/m	3 A/m	Power frequency magnetic fields should be at levels characteristic of a typical location in a typical commercial or hospital environment.
NOTE: 'Ut' is the AC mains voltage prior to application of the test level.			

Guidance and manufacturer's declaration - Electromagnetic Immunity			
The product is intended for use in the electromagnetic environment specified below. The customer or the user of the product should assure that it is used in such an environment.			
Immunity test	IEC/EN60601 test level	Compliance level	Electromagnetic environment – guidance
Conducted RF EN/IEC61000-4-6	3Vrms 150kHz to 80MHz	3Vrms	Portable and mobile RF communications equipment should be used no closer to any part of the product, including cables, than the recommended separation distance calculated from the equation applicable to the frequency of the transmitter.  Recommended separation distance $d=1.2 \sqrt{P}$ $d=1.2 \sqrt{P}$ 80MHz to 800MHz $d=2.3 \sqrt{P}$ 800MHz to 2.5GHz Where P is the maximum output power rating of the transmitter in watts (W) according to the transmitter manufacturer, and (d) is the recommended separation distance in meters (m). Field strengths from fixed RF transmitters as determined by an electromagnetic site survey(a) should be less than the compliance level in each frequency range(b). Interference may occur in the vicinity of equipment marked with the following symbol: 
Radiated RF EN/IEC61000-4-3	3V/m 80MHz to 2.5GHz	3V/m	
NOTE 1: At 80MHz and 800MHz, the higher frequency range applies.			
NOTE 2: These guidelines may not apply in all situations. Electromagnetic propagation is affected by absorption and reflection from structures, objects and people.			
a: Field strengths from fixed transmitters, such as base stations for radio (cellular/cordless) telephones and land mobile radios, amateur radio, AM and FM radio broadcast and TV broadcast cannot be predicted theoretically with accuracy. To assess the electromagnetic environment due to fixed RF transmitters, an electromagnetic site survey should be considered. If the measured field strength in the location in which the product is used exceeds the applicable RF compliance level stated above, the product should be observed to verify normal operation. If abnormal performance is observed, additional measures may be necessary, such as reorienting or relocating the product.			
b: Over the frequency range 150kHz to 80MHz, the field strength should be less than 3V/m.			

## EMC Information (Electromagnetic Compatibility Information)

Cables and accessories	Maximum length	Complies with
Link cable	1.0m (Unshielded)	RF emissions, CISPR11, EN55011 Class B / Group 1 Electrostatic discharge (ESD): EN/IEC61000-4-2
AC adaptor cord (Secondary side)	5.0m (Unshielded)	Electrical fast transient/burst: EN/IEC61000-4-4 Surge: EN/IEC61000-4-5
AC adaptor cord (Primary side)	2.0m (Unshielded)	Voltage dips, short interruptions and voltage variations on power supply input lines: EN/IEC61000-4-11
Motor cord	2.2m (Unshielded)	Power frequency(50/60Hz) magnetic field: EN/IEC61000-4-8 Conducted RF: EN/IEC61000-4-6 Radiated RF: EN/IEC61000-4-3

### Recommended separation distances between portable and mobile RF communications equipment and the product

The product is intended for use in an electromagnetic environment in which radiated RF disturbances are controlled. The customer or the user of the product can help prevent electromagnetic interference by maintaining a minimum distance between portable and mobile RF communications equipment (transmitters) and the product as recommended below, according to the maximum output power of the communications equipment.

Rated maximum output power of transmitter W	Separation distance according to frequency of transmitter m		
	150kHz to 80MHz $d=1.2 \sqrt{P}$	80MHz to 800MHz $d=1.2 \sqrt{P}$	800MHz to 2.5GHz $d=2.3 \sqrt{P}$
0.01	0.12	0.12	0.23
0.1	0.38	0.38	0.73
1	1.2	1.2	2.3
10	3.8	3.8	7.3
100	12	12	23

For transmitters rated at a maximum output power not listed above, the recommended separation distance "d" in meters (m) can be estimated using the equation applicable to the frequency of the transmitter, where "P" is the maximum output power rating of the transmitter in watts (W) according to the transmitter manufacturer.

NOTE 1: At 80MHz and 800MHz, the higher frequency range applies.

NOTE2 : These guidelines may not apply in all situations. Electromagnetic propagation is affected by absorption and reflection from structures, objects and people.

**NAKANISHI INC.**  [www.nsk-dental.com](http://www.nsk-dental.com)  
700 Shimohinata, Kanuma, Tochigi 322-8666, Japan

**NSK Europe GmbH**   
Elly-Beinhorn-Strasse 8, 65760 Eschborn, Germany

Specifications are subject to change without notice.



Visit our website

Issued Date: 2021.04.22  
Printed Date: 2021.04.30 003 (H)